

Log Homes, Politicians, and the Economy

For better or worse, we are in a time of "change". Some of our clients are taking a "wait and see" stance. Others are taking the path of "now or never". What is your direction? Perhaps we can give you some thoughts to consider that will help you "off the fence".

Current mortgage rates are near all-time lows, building materials are at a 26 year low and contractors are actually looking for work. And just like everyone else, the log home industry is looking for business. Now is a great (you might say the best) time to build.

Waiting will allow you to see if prices continue to go lower. If the economy rebounds, your investments will be worth more. But mortgage rates will increase, prices will rise, building material cost will rise, labor cost will go up. Time stands still for no one.

It's not likely that "the powers in Washington" will bail out the log home industry. They are too busy taking over auto, banking, financial and soon medical. Several log home companies have ceased operations. (If you had a deposit in with another log supplier, we may be able to help.) We have several ways to get you started with plans now to build later.

There's also the "I can't sell my current home". While in many case that may be true, many times it's more likely "I can't sell my home for what I was told it was worth 2 years ago". (Time machines aren't readily available, but if you find one let me know.)

What's the next step? Why not sit down at the dining room table, get out all those log

home magazines, some paper and a pencil or two, and put your ideas for what you want that dream log home to look like. Imagine your possibilities.

And if you want, we'll sit down with you and help plan "your home, your way". (Just make sure you have plenty of Dr. Pepper or iced tea.)



A great place to sit and plan

The Log System is your most important decision (make the right choice)

Cedar LogSystems' air and moisture seal is an integral part of our log home system. If you have a great log (Cedar) and a great window and door (Eagle), then all you need is an incredible seal system (ButyLog®).

Our logs have the "look" of Swedish cope saddle notch (see "A" on drawing). That's where the similarity stops.

The ButyLog® is placed on both sides of the wide tongue (see "B" on drawing). This creates a 5" air seal barrier between the interior and exterior air temperatures.

The horizontal interface between logs is one of the "energy bandits" in a log home. In a Cedar LogSystems' log wall that interface area is nearly 6" in width.

ButyLog® is also used at all vertical joints (see "B" on drawing). The Colorado Corner is mortise and tenon, not butt and pass, with an 8" Assy® Fastener (see "C" on drawing) placed horizontally to secure the tenon into the mortise at all corners.

Cedar LogSystems uses 12" Assy® Fasteners (see "C" on drawing) to secure logs together. This allows for a much tighter fit between individual log courses. No other fastening system has the "pull down" of the Assy® Fastener. This helps to minimize the effects of shrinkage and settling.

All logs (all wood) move. Cedar LogSystems uses cedar bucks (see "D" on drawing) with aluminum "spline" to allow for that movement. These bucks allow the logs to move up or down without affecting the window or door operation. The window and door trim is applied to the buck and window, and is not attached to the log. This creates a "unit" around which the logs can freely move, independent of the window or door unit.

Your Cedar LogSystems' log home will be low maintenance and energy efficient for centuries to come.

Ask for a demonstration of the Colorado Corner and of the Cedar "LogSystem".

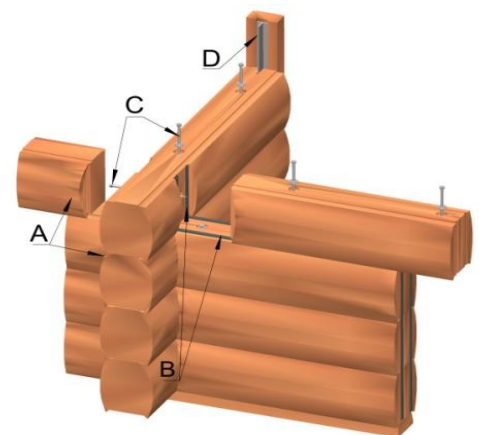

Colorado Corner - get into "the corner"

Remember

Caulk is a "maintenance" product.

If you don't caulk your log home, you'll never have to re-caulk your log home!

(Dumb, but true)

The BOGO/50% Special - Log and Cedar Specialties for deliveries by 04.15.2010

Start Here



2x6 Cedar Deck	2x10 Cedar Siding	1x10 Cedar Siding	1x10 Cedar Trim	1x8 Aspen T&G
----------------------	-------------------------	-------------------------	-----------------------	---------------------



**This is "the best" for 2010
Buy One, Get one at 50%
on all *in-stock* Specialties - no limits**

(Log Home Package purchase & delivery required)

Specialty products we offer include:

- 2 x 6 Cedar decking
- Log posts, rafters, joists
- 1x Cedar trim
- 1 x 8 Aspen T & G
- 2x Cedar (s.o.)
- Exterior stain and seal
- Log siding and corners
- 1 x 8 Cedar V & G (s.o.)
- Timber posts, rafters joists

Details - This promo CAN be combined with any of the promos at right or below. Not valid on any existing sales agreement. A 30% deposit is required on all Log and Cedar Specialties (50% on special order materials). Garage/basement windows and doors are not eligible for this promotion (already offered at CLSI cost). Minimum Log Home package purchase is \$75K for this promo. Delivery dates subject to prior bookings. Note: Delayed delivery, for any reason, will automatically cancel this BOGO 50% offer.

The "\$1,000 & 1% Promo A great way to start your future log home with price protection

North Carolina



**\$1,000 Down - 1% per month
12 month price guarantee**

- First preliminaries
- Second preliminaries
- Final plans
- Take your time
- Study your plans
- Make changes

And after 12 months
if you still aren't ready
we'll even extend your timing

This is a great "get started" Promo. With the plans in this package your contractor can bid out your entire project. Then when you are ready just apply for your permit and then dig, pour, stack, roof, finish and move in. Call today!

Details - This promo cannot be combined with any other promo, past or current. Not valid on any existing sales agreement. \$1,000 initial deposit to start your log home plans. Then 10 monthly payments of 1% of the log home package price for a total of 10% down. At the end of the time you will have the option to renew the promo, subject to wholesale cost increase only, or, of course, schedule your delivery. Note: Timing for plan turnaround is longer for this promo, generally averaging 30 days between plan sets.

The "One Log, Two Gun" Deal purchase your log home package and receive 2 AR-15 rifles

Bushmaster AR-15 (models vary)



This is our first time to offer a "non-log, non-lumber" bonus when you purchase one of our log home packages.

No Apologies - No Compromises

If you understand this promo, then no explanation is needed.

If you don't, no explanation would help. "We the people..."

... the right of the people to keep and bear arms, shall not be infringed. 2nd Amendment, Bill of Rights - 1791

10% Down - 12 month guaranteed price protection

This promo includes: preliminaries, second preliminaries, final plans and a 12 month (365 days) price lock...

Plus - 2 "American Made" AR-15s

Take as much time as you like planning your ultimate log home

Study the prelims, take your time, return them for rework, then have finals for your contractor

This is the "best of the best" Have your guns and shoot them too Call for additional details

Details - This promo cannot be combined with any other promo, past or current. Not valid on any existing sales agreement. Client must pass firearms background check. Subject to all applicable laws. Pick up is in Colorado Springs, CO. Any out-of-state shipping is the client/customer responsibility. Firearms dealer may be out of stock of this particular firearm and firearms of equal value may be substituted. The value for this promo is ~\$3,000. Note: The 10% initial deposit to CLSI will be non-refundable with this promo.

The DSA Design Service Agreement - get your dream on paper



This agreement offers you 1/4" scale plans with both floor plans and four elevations. More than enough to get preliminary price estimates, subdivision approval and even start your mortgage application. Then when you're ready to move forward, your full \$2,800 is applied to your log home package cost. Ask an architect if he'll do the same.

\$2,800 total up front

12 month price guarantee

1/4" scale drawings

Floor plans - main, upper, lower (if app'l)

Elevations - front, rear, left, right

Study, plan, dream and when you're ready...

transfer your \$2,800 plan fee

to your log home package

at anytime within two years

If you aren't sure of your timing

this is your option

Details - This promo cannot be combined with any other promo, past or current. Not valid on any existing sales agreement. Full amount will be converted to sales agreement. Log Home packages will be priced at the time the design fee is transferred to your actual Sales Agreement. A designer site visit is available for an additional fee. Note: Only first preliminaries are included in this offer, - for changes and final plans you will need to transfer your deposit to a standard Sales Agreement.

CEDAR LOG SYSTEMS

PO Box 25250
Colorado Springs
CO 80936-5250

800-600-5647
www.logs.net info@logs.net

Fall Promotions
pages 2-3

Food for Thought!

Inside is the best promo package we've ever offered. These promos give you "choices"... in timing, value, and premiums.

We believe now is the best time to build your dream. Visit us here in Colorado Springs. Schedule a site visit at one of our construction sites. Or set an appointment and we'll visit your property to help design your home.

When will you have a better opportunity to make your dream your reality? Most of us aren't getting any younger. Your children and grandchildren want you to build your log home so they can come visit. (Who are we kidding? They want to see what they'll inherit!)

Get started before the government.... ???

Direct comments to Charles at 719.235.8242

Log Homes - Custom Design - Custom Build - Nationwide

Not everyone is "sitting on the fence" - Here are some recent log home starts



Colorado

Colorado

Idaho

California